

Pure Freude
an Wasser



GROHE BAULINES – WHAT IS NEW?

Customers' demands in terms of high-quality solutions and state-of-the-art design are continually increasing. The new GROHE Baulines perfectly meets these needs with additional product features and a modernised design in two styles: The cubist BauEdge and the light BauLoop.



Improved user experience
due to angled mousseur



Reduced design: slim, short
lever for improved interaction



Clear cut lines in
cosmopolitan design

AN ALL-ROUNDER: A SOLUTION FOR EVERY CUSTOMER AND PROJECT

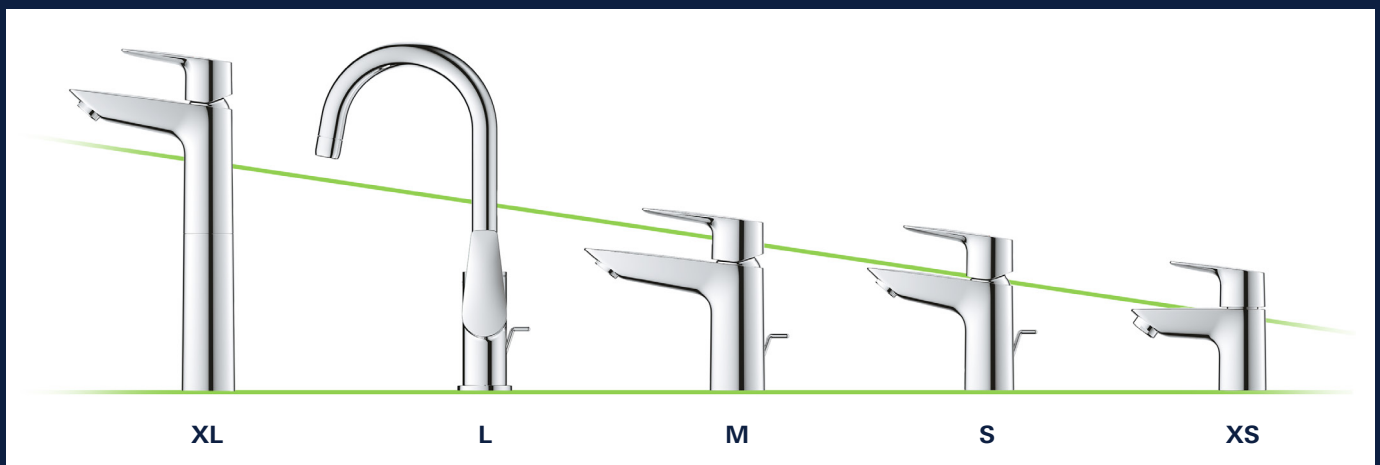

GROHE Baulines is an all-rounder. Available in a total of five sizes – there is a solution for any bathroom concept. All models are available in a classic Chrome finish and support a sustainable lifestyle, thanks to an array of water and energy-saving technologies.

PART OF **LIXIL**

Pure Freude
an Wasser



GROHE BAULINES PRODUCT PORTFOLIO – COMPLETE BATHROOM SOLUTIONS

The GROHE Baulines product portfolio allows for convenient and modern bathroom planning in a few simple steps. In addition to the GROHE Baulines basin mixer, a variety of brassware for the bathtub, shower and bidet are also available.

GROHE Baulines enables you to provide your customers with complete bathroom solutions from one single source as Baulines brassware can be perfectly complemented with GROHE's Bau Ceramic range. The ranges have been through rigorous testing to ensure ultimate compatibility in form and function, which prevents avoidable issues such as water splashing when using the tap. To complete the collection is the addition of the New Bau Ceramic Slim Seat. Thanks to its sleek and contemporary look it upgrades any WC and furthermore offers modern comfort with the SoftClose feature and easy cleaning thanks to the QuickRelease function. Finally the **Bau Accessories** can add the final touches to a coordinated bathroom.



BATH MIXER



Exposed



Concealed



Trim for Smartbox



Bath Spout

SHOWER MIXER



Exposed



Concealed



Trim for Smartbox

BIDET



PART OF **LIXIL**

Pure Freude
an Wasser



THE GROHE BAULINES PORTFOLIO BENEFITS FROM THE LATEST ADVANCEMENTS IN TECHNOLOGY:

GROHE Triple Core

GROHE TripleCore: Thanks to its innovative zinc die casting process at the LIXIL plant in Klaeng, Thailand, one of the most sustainable plants in South East Asia, GROHE taps offer safe water enjoyment. Not only is **the surface of the tap seamlessly closed** so that impurities cannot enter, there are also dedicated inner waterways to **make sure that the water does not make contact with any lead or nickel**. Above that these inner waterways have no contact to the body material which result in a **barrier between hot water and the external surface to avoid scalding on hot surfaces**.



GROHE StarLight: Made-to-last Chrome surfaces. The flawless, long-lasting surface is designed to be extremely resistant to dirt and scratches, making maintenance effortless and ensuring good-as-new looks for many years.



GROHE EcoJoy: While a flow restrictor limits water flow from 10 to 5.7 litres per minute, an aerator enriches the water with air to create a voluminous shower experience, which helps to save precious resources without compromising on performance.

GROHE LowFlow: Specific Bauline variants come with the LowFlow feature, which reduces the water flow to 3.5 litres per minute.



SilkMove ES: The intelligent combination of energy-saving and effortless water control. Specific product variants like the BauLoop S-size or the BauEdge M-size come with cold start technology. Using the mid-lever position for cold water, these models reduce wastage of hot water, saving precious water and energy.



PART OF **LIXIL**

Pure Freude
an Wasser



GROHE BAULINES FOR FUNCTIONALITY IN THE KITCHEN

Alongside the coordinated bathroom solutions, GROHE Baulines also offers kitchen taps that harness the very latest in functionality and design. Thanks to smart technologies, the Bauline kitchen tap is easy to install making it a cost-efficient solution for the installer or kitchen fitter.



GROHE BAULINES KITCHEN PORTFOLIO

GROHE Baulines kitchen is available in round and square design options, as well as low, medium and high spout variants ensuring there is an ideal solution for every customer and project. All spouts offer an optimal height spout position, allowing for convenient operation for cooking and cleaning tasks.



GROHE BauEco
sink mixer low spout



GROHE BauEdge
sink mixer medium spout



GROHE BauCurve
sink mixer medium spout



GROHE BauLoop
sink mixer high spout



GROHE BauFlow
sink mixer high spout



GROHE BauClassic
sink mixer high spout

PART OF **LIXIL**

Pure Freude
an Wasser



FEATURES FOR SAFETY AND SIMPLICITY

EASY INSTALLATION AND CONVENIENT MAINTENANCE



The installation of the new kitchen tap is particularly easy thanks to the GROHE Fast Fixation system. Shaft-coupling and pre-assembled items enable a fast, hassle- and completely tool-free fitting.



Clean and replace the mousseur in the tap quickly with total ease thanks to the clever coin-slot Easy Exchange feature.

SAFE WATER CONSUMPTION



To add to its innovative functionality, all GROHE Bau kitchen taps are equipped with the GROHE Zero technology. Dedicated inner waterways within the mechanism of the tap ensure that the water does not come into contact with lead or nickel. Above that these inner waterways have no contact to the body material which result in a barrier between hot water and the external surface to avoid scalding on hot surfaces.

COMPLETE KITCHEN SOLUTIONS

For a coordinated and modern kitchen space that offers easy kitchen planning for designers, the GROHE product portfolio also offers a choice of stainless steel sinks, like GROHE K200, to complete the kitchen tap area. For a bolder, design-led upgrade, GROHE Composite sinks in Granite Grey and Granite Black are also compatible with the Baulines tap range.



For high resolution images of GROHE Baulines for bathroom and kitchen click the following Link: <https://bit.ly/3t6sMIb>

GROHE

World Business Centre 2 | Newall Road |
London Heathrow Airport | Hounslow | Middlesex | TW6 2SF
Phone: 0208 283 2840 | www.grohe.co.uk

MEDIA CONTACT

Jasmine Burford | DMC PR
E-Mail: jasmine@dmcpr.co.uk

PART OF **LIXIL**